

# Enphase Energy System planning guide for grid-agnostic IQ Battery 5P with FlexPhase

**Applicable regions: Austria, Germany, Switzerland**

© 2024 Enphase Energy. All rights reserved. Enphase, the e and CC logos, and certain other marks listed at <https://enphase.com/trademark-usage-guidelines> are trademarks of Enphase Energy, Inc. in the U.S. and other countries. Data subject to change.

## 1. About this document

This guide contains information for site surveyors and design engineers to analyze a site and plan the design, installation, and support of home energy systems using the grid-agnostic Enphase Energy System (EES). This guide is not for installation and operation. This document supplements the information in the data sheets, quick install guides (QIGs), and product manuals. The diagrams and information are demonstrative of system configurations and installations. However, they may not include all additional local standards and regulations applicable to a site.

## 2. Enphase Energy System overview

The following table lists the three use cases supported by EES.

*Table 1: Use cases*

Energy sources at the site	Description
Solar Only (backup ready)	<p>This configuration is ideal for homeowners who want to go solar and optimize their electricity bill savings.</p> <p>By producing and consuming the electricity generated from their solar plant, homeowners reduce their dependence on the grid and go green.</p> <p>When installed with the IQ System Controller and IQ Battery 5P with FlexPhase in the future this system will have backup capability.</p>
Solar plus Battery	<p>Pairing IQ Microinverters with IQ Batteries and IQ System Controller, this configuration combines solar and storage to help maximize financial benefits, increase self-consumption, and also provide power backup to the home in the event of a grid outage.</p> <p>A Solar plus Battery system apart from providing power backup makes a home more energy-independent and can offer significant long-term savings by minimizing the homeowner’s electricity bills. In this configuration, the microinverters power the house with solar energy when the sun shines. Excess solar energy is used to charge the IQ Batteries. Once the battery is fully charged, the extra solar energy is exported back to the grid in exchange for electricity bill credits (in countries that allow it). Once the sun sets, the battery powers the home.</p>
Battery upgrade (installed on existing PV site)	<p>If a home has an existing solar system—either Enphase solar or a string inverter system—adding IQ Batteries can help maximize financial benefits by storing excess solar power. Use this stored energy to power the home once the sun sets.</p>

### 3. Product overview

- IQ Series Microinverters and accessories:** IQ Series Microinverters pack more power into less space than other rooftop solar systems and make rooftop solar more productive, reliable, smart, and safe.
- IQ Battery 5P with FlexPhase:** This is an all-in-one AC-coupled battery system, that is powerful, reliable, simple, and safe. The battery can be flexibly used in both single-phase and three-phase applications. It has a total usable energy capacity of 5.0 kWh and includes six embedded IQ8T-BAT Microinverters providing up to 3.84 kVA continuous power in single-phase configuration (country-specific ratings may vary) and 1.28 kVA continuous power per phase in three-phase configuration.
- IQ System Controller 3 INT:** The IQ System Controller 3 INT consolidates the connection of the home to the public electricity grid, the IQ Battery 5P, and the IQ7 or IQ8 Microinverter all in one compact enclosure. It provides automatic transfer switch (ATS) functionality by automatically detecting and transitioning the home energy system from grid power to backup power in the event of a power outage. It consolidates interconnection equipment, IQ Gateway Metered, and IQ Relay functionalities into a single enclosure and streamlines grid-independent operation capability with a consistent, pre-wired solution, including CTs.
- Control cable:** The control cable enables communication between the IQ Gateway and the IQ Battery 5P with FlexPhase.

### 4. Product generation and interoperability

Table 2: Supported and unsupported configurations with the IQ Battery 5P

Product	IQ Battery 5P with FlexPhase-grid agnostic + IQ System Controller-Backup
IQ7 Series	Yes
IQ8 Series	Yes
IQ7 Series and IQ8 Series	No <sup>1</sup>
M Series	No <sup>2</sup>
IQ7/IQ8 Series and M Series	No <sup>2</sup>
String inverter	Yes <sup>3</sup>
String inverter and IQ7/IQ8 Series	Yes <sup>4</sup>
AC Battery	No <sup>5</sup>
IQ Battery 3T/10T	No <sup>5</sup>

<sup>1</sup> IQ7 and IQ8 Series Microinverters can't be supported on the same IQ Gateway/IQ System Controller 3 INT. The IQ Battery 5P should be installed on the IQ System Controller 3 INT with the IQ7 or IQ8 and a separate IQ Gateway is needed for the additional PV. A PLC filter is required to segregate the PLC of the IQ System Controller and IQ Gateway. A Bialon FF-01 line filter can be used for PLC signal isolation.

<sup>2</sup> M Series Microinverters and the IQ Battery 5P with FlexPhase need to be installed on separate gateways.

IQ7/IQ8 Microinverters can be installed on the same gateway/IQ System Controller 3 INT as IQ Battery 5P with FlexPhase.

<sup>3</sup> For sites having a third-party string inverter, it is mandatory to wire the power terminal of the string inverter through an external NO (Normally Open) contactor to the I/O board of the IQ System Controller 3 INT which shall allow the string inverter

to stay connected when PV to Battery ratio is  $\leq 100\%$  of rated power per phase, and when PV to battery ratio is  $> 100\%$  of rated power per phase, shed the string inverter in off-grid operation.

<sup>4</sup> This is supported for sites without a power export limit (PEL) for on-grid operation. Consideration for string inverter wiring through NO (Normally Open) contactor as mentioned above applies here as well.

<sup>5</sup> AC Battery and IQ Battery 3T/10T are not compatible with IQ Battery 5P with FlexPhase because the mode of communication for the prior generations (PLC/wireless Zigbee) and IQ Battery 5P with FlexPhase (CAN communication) are not compatible with each other.

## 5. Design an Enphase Energy System

### 5.1 System profiles

The Enphase Energy System supports the following system profiles of operation:

- **Self-Consumption:** The PV system and battery are optimized to enable maximum self-consumption of energy produced by the PV system. The battery's capacity caters to home loads to minimize energy import from the grid.
  - Charge-from-grid: This is an advanced battery setting in the self-consumption profile where the battery can charge from the grid during a specific schedule set by the user.
  - Discharge-to-grid: This is an advanced battery setting in the self-consumption profile where the battery can discharge to the grid during a specific schedule set by the user
- **AI Optimization:** Maximizes savings by using electricity rates, consumption patterns, and solar forecast. Works with "Time of Use" or dynamic tariff rates in regions where applicable. Consult local websites for availability in your country.
- **Full-Backup:** This profile is for providing backup power from the PV and battery system in the event of a grid outage. During on-grid operation, the battery would charge from PV or from the grid to reserve 100% of the capacity for backup operation. The battery will only discharge in the event of a grid outage. This mode is only supported if an IQ System Controller is installed in the system.

 **NOTE:** All above modes are applicable for the on-grid operation of the system.

### 5.2 System considerations

Read each product's quick install guides (QIG) for detailed information about installing the Enphase Energy System.

Below are key considerations that need to be taken at a system level for the Enphase Energy System:

- **Solar only (Backup ready):** Installers are suggested to procure the IQ System Controller and connect the IQ Microinverter to designated PV terminals via the IQ Cables. Separate IQ Gateway, CTs, and IQ Relay are not required as these products are integrated inside the IQ System Controller itself. IQ Batteries can be added in the future to the designated battery phase terminals to provide backup to the house.
- **Solar plus Battery grid-agnostic operation:** For all new grid-agnostic system (on-grid and backup) installations installers are required to procure the IQ Microinverters, IQ Battery, and IQ System Controller and connect as per the shown wiring diagrams in the section below.
- **Retrofit (Battery upgrade on existing PV site):** For retrofitting IQ Battery to an existing IQ Microinverter PV-only system for backup, installers are required to remove the existing IQ Gateway, IQ Relay, Production and Consumption CTs from the site. The IQ Microinverter can

be directly connected to the designated terminals in the IQ System Controller on all three phases, similarly, the IQ Battery can be connected to the battery terminals in the IQ System Controller.

Below are key considerations that need to be taken for components of the Enphase Energy System.

**IQ System Controller 3 INT**

- PV, IQ Battery, load, and mains breakers/RCDs/RCBOs should be sized as per local requirements and cable sizes used on site. These are not supplied with the IQ System Controller 3 INT. An additional enclosure may be required to house all disconnection components.
- When wiring power cables from the grid supply, PV, and battery onto the IQ System Controller 3 INT lugs for the main, PV, and IQ Battery respectively, ensure that you correctly terminate the L1, L2, and L3 cables on the designated L1, L2, and L3 lugs as indicated on the label (shown below) of the IQ System Controller 3 INT. Failure to do so will result in an incorrect phase sequence and render the system non-operational.



- A local earth electrode is recommended to ensure safe operation during backup scenarios. Follow local electrical regulations and best practices.
- The earthing systems supported are TN-C-S, TN-S, and TT. The earthing systems that are not supported are TN-C and IT.
- It is recommended to wire ALL home loads through the IQ System Controller. Size the backup circuit based on the number of batteries on site and the rest of the loads should be wired to the non-backup circuit. Wiring ALL loads through the IQ System Controller ensures that the pre-wired Consumption CTs function as desired.
- The IQ System Controller 3 INT has four auxiliary contacts (two are normally closed – IO1 and IO2; two are normally open – IO3 and IO4). Apart from IO1 (normally closed) which is reserved only for third-party string inverters, the remaining I/Os can be used for load shedding in off-grid operation. Refer to the tech brief on third-party string inverter and load shedding configuration on the Documentation center.
- For sites with a third-party string inverter, it is mandatory to wire the power terminal of the string inverter through an external NO (Normally Open) contactor to the I/O board of the IQ System Controller 3 INT which shall allow the string inverter to stay connected when PV to Battery ratio is ≤100% of rated power per phase and when PV to battery ratio is >100% of rated power per phase, shed the string inverter in off-grid operation. Refer to the tech brief on third-party string inverter configuration on the Documentation center.

✓ **NOTE:** The contacts on the I/O board of the IQ System Controller 3 INT are rated for a maximum of 1 A at 230 VAC RMS. A sample contactor that can be used is Hager ESC425.

**IQ Microinverters:**

- Determine the length and cross-section of the AC conductor between the junction with the IQ Cable and the electrical panel per the local electrical regulations. It is recommended that the voltage drop across these conductors does not exceed 1% and that the overall voltage drop in the PV circuit from the point of connection to the most remote microinverter does not exceed 2%. Depending on the size of the PV system and the length of the cable, the cross-section in the supply line must be increased.
- Install any equipotential bonding between PV module frames, array mounting structures, and metal microinverter mounting brackets per local electrical regulations.
- In three-phase systems, microinverters should be balanced across the three phases to avoid phase imbalance.
- Generally, a 20 A B-curve circuit breaker is installed to protect the 2.5 mm<sup>2</sup> IQ Cable per PV circuit. Ensure your microinverters in the branch circuit do not exceed 16 A. However, it is essential to understand and follow local regulations where this may not be the case.
- Surge protection devices (SPD) and residual current devices (RCD/FI) must be installed in accordance with the electrical standards applicable in the country of installation. Enphase microinverters have an integrated SPD device of type III.
- The microinverters contain an RF transformer that ensures the function of galvanic isolation between the DC PV module and the AC network. In accordance with this, Type A or Type B RCDs may be required depending on the electrical standards applicable to the installation.
- Enphase offers a multi-phase 4-core (L1, L2, L3, N) or single-phase 2-core (L + N) cable with 2.5 mm<sup>2</sup> (Q-RAW, H07BQ-F, UV-resistant and maximum operating temperature of 90°C) as a supply line or as an extension of the IQ Cable. If the cable length and the associated voltage drop are too great, a larger cross-section with a 3 or 5-core NYM, NYY, or comparable cable must be used depending on the type of installation and location.
- PV systems >30 kVA must be equipped with central grid coupling protection.

**IQ Battery 5P with FlexPhase:**

**NOTE:** Sites with a combination of IQ Battery 5P with FlexPhase configured as single-phase and three-phase are not supported. All the batteries on site can either be configured as three-phase or single-phase.

- The IQ Battery 5P with FlexPhase is shipped with the jumper block pre-installed on the AC terminals making it a one-phase battery by default. To utilize the battery in three-phase configurations, simply pull out/remove the jumper block from the AC terminals.
- In three-phase systems, it is recommended to install the IQ Battery 5P with FlexPhase across three phases for balanced operation. Installing the battery as a single-phase device can result in phase imbalance and system performance issues.
- Up to five IQ Battery 5P units in a three-phase configuration can be connected on a single circuit.
- The battery terminals are compatible with a conductor size between 2.5–10 mm<sup>2</sup> (without ferrule) in three-phase configurations. Use a 10 A B curve circuit breaker for one IQ Battery 5P or a maximum 40 A B curve circuit breaker for five IQ Battery 5P units. Follow all local standards and regulations while selecting the AC circuit breaker.
- Any system with an IQ Battery installed must have Wi-Fi or Ethernet as the primary mode of internet connectivity.

**Others:**

Installers must procure a suitable length of the control cable for the installation. Procure the required length of the control cable from your Enphase distributor. The Enphase order code for the cable is CTRL-BL-EU-01.

 **NOTE:** Enphase requires the use of an Enphase Control Cable for optimal performance of the Enphase Energy System. Enphase cannot guarantee performance when a third-party cable is used.

### 5.3 System sizing guidelines

When sizing the PV and battery system for on-grid and backup operation the below considerations on the limits to be followed.

1. Total grid supply connection to IQ System Controller 3 INT cannot exceed 80 A per phase.
2. The total installed capacity for PV and battery each cannot exceed 80 A per phase. Refer to the below tables to understand the maximum allowed PV and battery counts.

 **NOTE:** Although the PV and battery installed can be 80 A per phase each, the total output power from both PV and battery collectively will be controlled via software to never exceed 80 A per phase.

Table 3: With IQ7 Microinverters:

Configuration	Maximum count of IQ Battery 5P with FlexPhase	Maximum count of IQ7
Three-phase configuration	14	IQ7A - 50 per phase (total 150 per site) IQ7PLUS - 62 per phase (total 186 per site) IQ7 -74 per phase (total 222 per site)

Table 4: With IQ8 Microinverters:

Configuration	Maximum count of IQ Battery 5P with FlexPhase	Max count of IQ7
Three-phase configuration	14	IQ8HC - 47 per phase (total 141 per site) IQ8AC - 50 per phase (total 150 per site) IQ8MC -55 per phase (total 165 per site)

3. Total home loads (backup + non-backup) cannot exceed 80 A per phase.
4. For the Enphase Energy System of IQ Battery and IQ System Controller with IQ7 Microinverter, the ratio of PV power (in kW) to Battery power (in kW) should not exceed 150%.
5. For the Enphase Energy System of IQ Battery and IQ System Controller with IQ8 Microinverter, the ratio of PV power (in kW) to Battery power (in kW) should not exceed 200%.
6. For the Enphase Energy System of IQ Battery and IQ System Controller with third-party PV inverter, the ratio of PV power (in kW) to Battery power (in kW) should not exceed 100%.

Refer to the below table and calculate the total batteries a site would need depending on home load parameters.



**NOTE:** The following considerations need to be kept in mind for the below table.

- The below table considers the whole home backup use case where all the home loads are connected to the backup lugs on the IQ system Controller 3 INT
- The below table considers power and current as aggregate rating
- The total PV power that can be installed considers the PV-to-Battery ratio for IQ7 and IQ8 Microinverters
- The maximum day-time backup power from both PV and battery collectively will never exceed 80 A per phase (55.2 kW aggregate).

Table 5: For IQ7 Microinverters

Battery count	Total energy capacity (kWh)	Total battery power (kW)	Max supported PV (kW)	Maximum day-time backup power capability (kW)	Maximum night-time backup power capability (kW)
1	5	3.84	5.76	≤9.6	≤3.84
2	10	7.68	11.52	≤19.2	≤7.68
3	15	11.52	17.28	≤28.8	≤11.52
4	20	15.36	23.04	≤38.4	≤15.36
5	25	19.2	28.8	≤48	≤19.2
6	30	23.04	34.56	≤55.2	≤23.04
7	35	26.88	40.32	≤55.2	≤26.88
8	40	30.72	46.08	≤55.2	≤30.72
9	50	34.56	51.84	≤55.2	≤34.56
10	60	38.4	55.2	≤55.2	≤38.4
11	70	42.24	55.2	≤55.2	≤42.24
12	80	46.08	55.2	≤55.2	≤46.08
13	90	49.92	55.2	≤55.2	≤49.92
14	100	53.76	55.2	≤55.2	≤53.76

Table 6: For IQ8 Microinverters

Battery count	Total energy capacity (kWh)	Total battery power (kW)	Max supported PV (kW)	Maximum day-time backup power capability (kW)	Maximum night-time backup power capability (kW)
1	5	3.84	7.68	≤11.52	≤3.84
2	10	7.68	15.36	≤23.04	≤7.68
3	15	11.52	23.04	≤34.56	≤11.52
4	20	15.36	30.72	≤46.08	≤15.36
5	25	19.2	38.4	≤55.2	≤19.2
6	30	23.04	46.08	≤55.2	≤23.04
7	35	26.88	53.76	≤55.2	≤26.88
8	40	30.72	55.2	≤55.2	≤30.72
9	50	34.56	55.2	≤55.2	≤34.56
10	60	38.4	55.2	≤55.2	≤38.4
11	70	42.24	55.2	≤55.2	≤42.24
12	80	46.08	55.2	≤55.2	≤46.08
13	90	49.92	55.2	≤55.2	≤49.92
14	100	53.76	55.2	≤55.2	≤53.76

As a reference for electrical symbols, refer to the following legend to comprehend the system diagrams in a better way. The following sample Enphase Energy System diagrams help to design your PV and storage systems.

Add a line here stating that the IQ Battery 5P with FlexPhase can support a surge current of 33.4 A for 3 seconds and 26.7 A for 10 seconds per battery. This surge current helps handling of any surges from inductive loads in off-grid operation.

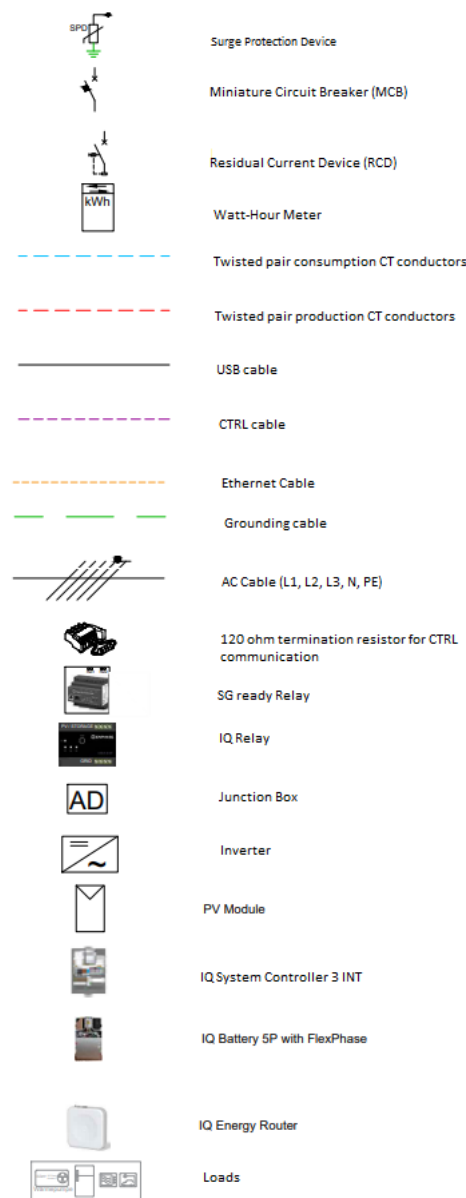
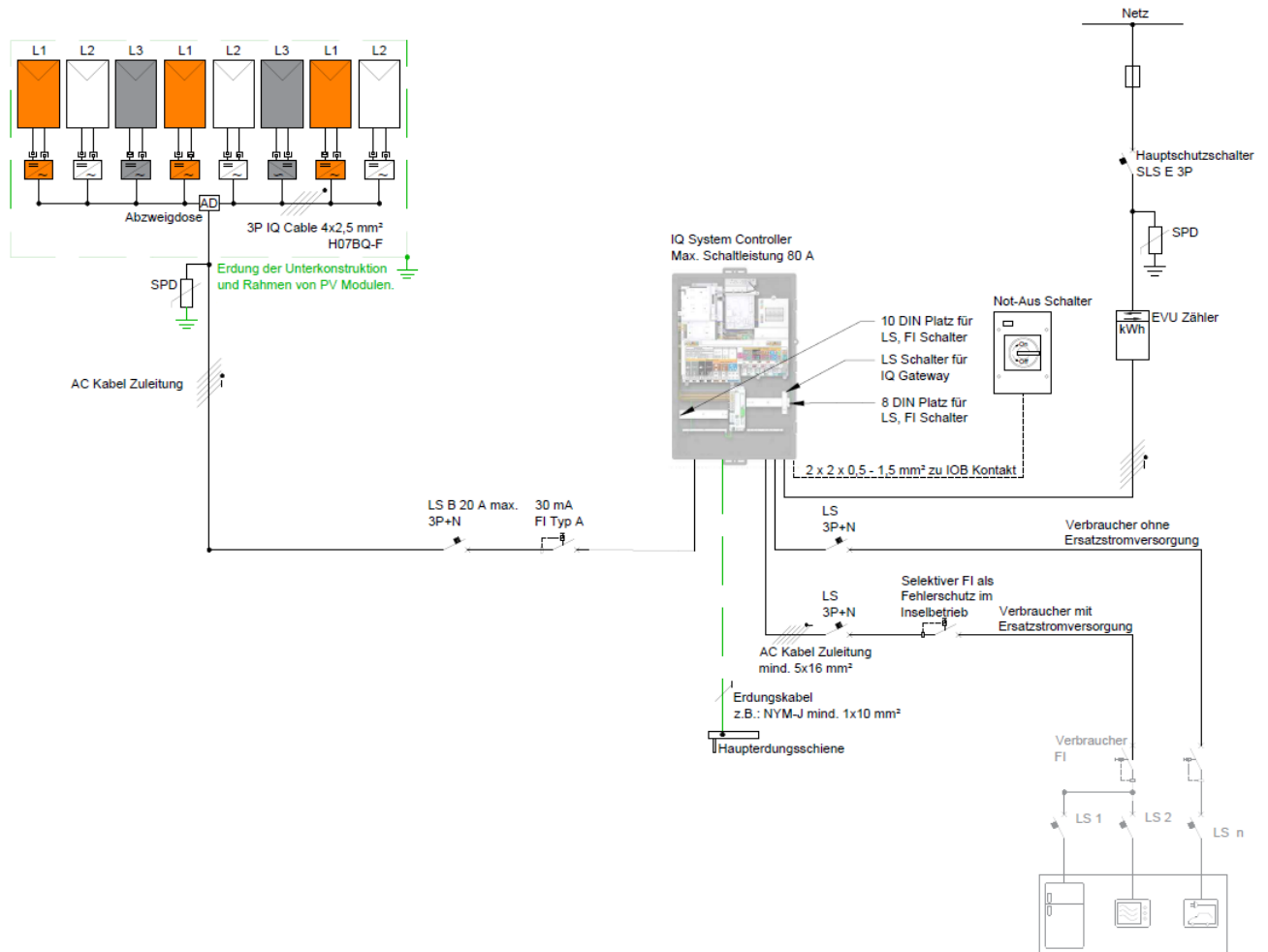

Figure 1: System diagram: Legends

The following sample Enphase Energy System diagrams help you design your PV and storage systems.

### 5.3.1 Solar PV only (backup ready): Three-phase IQ7/IQ8 Series Microinverters with IQ System Controller 3 INT



Um Ihre Materialliste mit Enphase-Komponenten zu erhalten, nutzen Sie unser System Builder-Tool auf unserer Website <https://enphase.com/de-de/installers/systems>.

Figure 2: Three-phase IQ7/IQ8 Series Microinverters only system with with IQ System Controller 3 INT diagram

### 5.3.2 Solar PV and battery: Three-phase IQ7/IQ8 Series Microinverters and IQ Battery 5P with FlexPhase configured in three-phase with IQ System Controller 3 INT

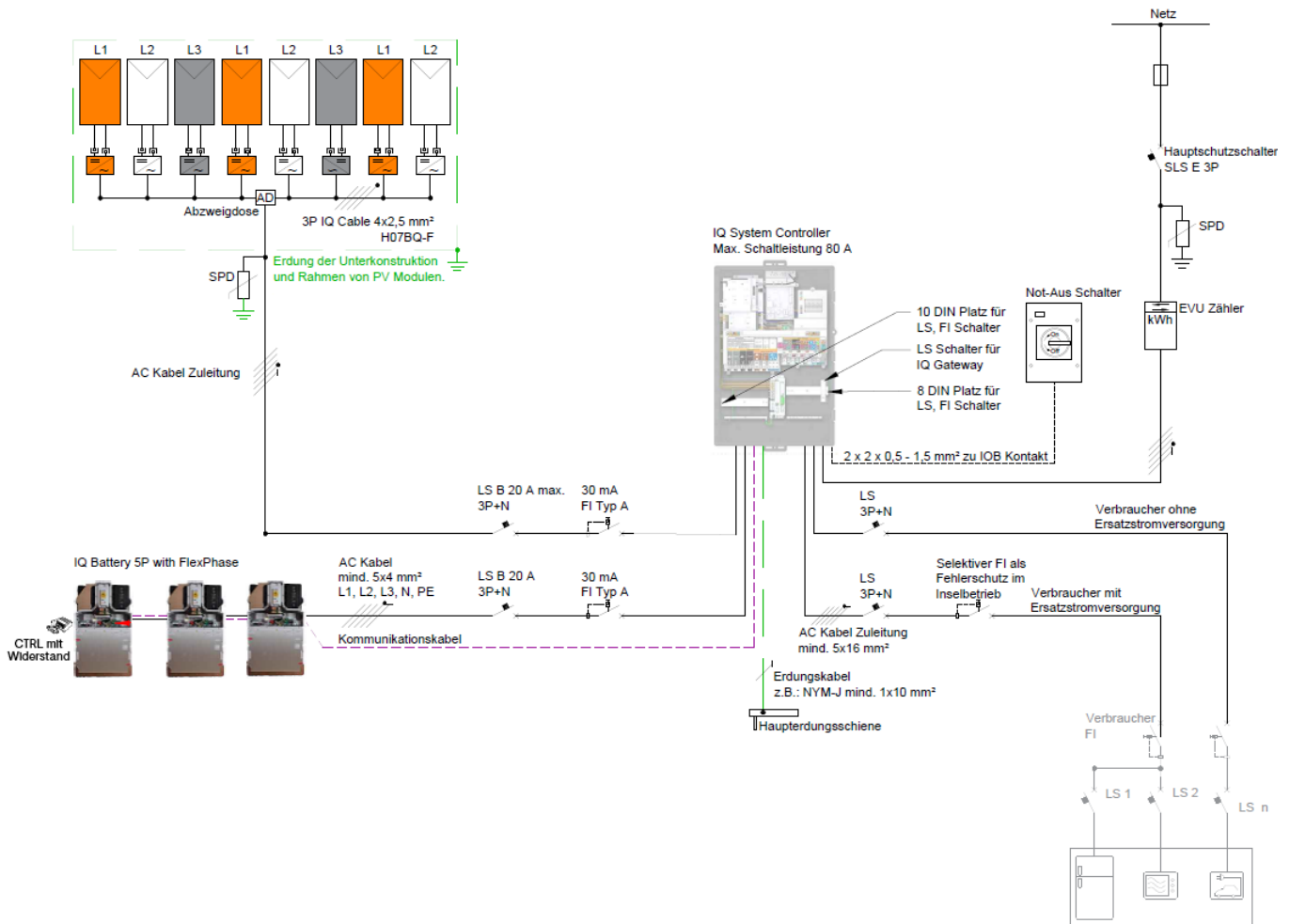

Figure 3: Three-phase IQ7/IQ8 Series Microinverters and IQ Battery 5P with FlexPhase configured in three-phase with IQ System Controller 3 INT diagram

### 5.3.3 Solar PV and batteries: Three-phase string inverter and IQ Battery 5P with FlexPhase configured in three-phase with IQ System Controller 3 INT

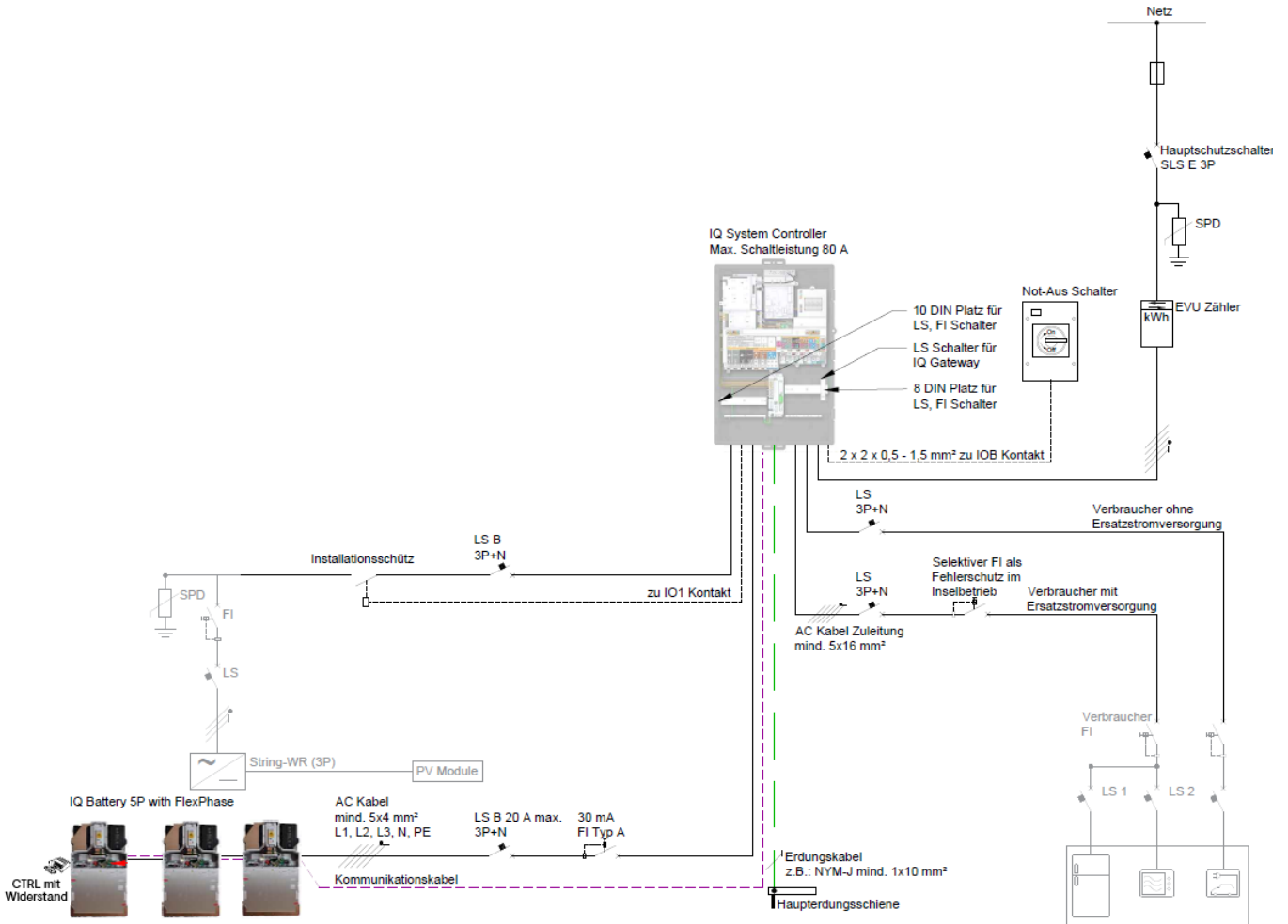

Figure 4: Three-phase string inverter and IQ Battery 5P with FlexPhase configured in three-phase with IQ System Controller 3 INT diagram



**NOTE:**

- For sites having a third-party string inverter, it is mandatory to wire the power terminal of the string inverter through an external NO (Normally Open) contactor to the I/O board of the IQ System Controller 3 INT which shall allow the string inverter to stay connected when PV to Battery ratio is  $\leq 100\%$  of rated power per phase, and when PV to battery ratio is  $> 100\%$  of rated power per phase, shed the string inverter in off-grid operation. Refer to the tech brief on string inverter configuration on the Documentation center.
- The contacts on the I/O board of the IQ System Controller 3 INT are rated for a maximum of 1 A at 230 VAC RMS. A sample contactor that can be used is Hager ESC425.

### 5.3.4 Solar PV and battery: Three-phase IQ7/IQ8 Series Microinverters and string inverter and IQ Battery 5P with FlexPhase configured in three-phase with IQ System Controller 3 INT

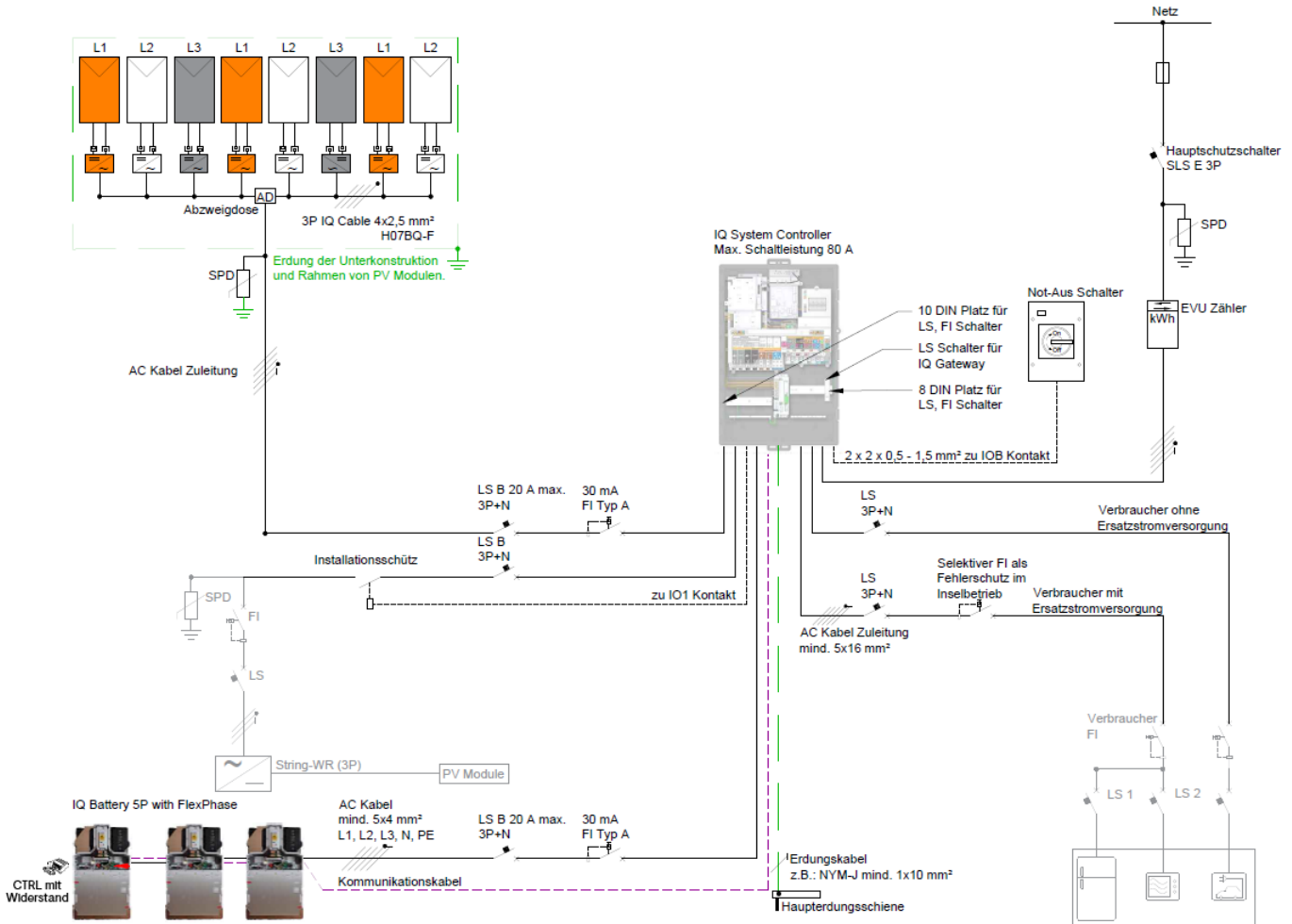

Figure 5: Three-phase IQ7/IQ8 Series Microinverters and string inverter and IQ Battery 5P with FlexPhase configured in three-phase with IQ System Controller 3 INT diagram



**NOTE:**

- For sites having a third-party string inverter, it is mandatory to wire the power terminal of the string inverter through an external NO (Normally Open) contactor to the I/O board of the IQ System Controller 3 INT which shall allow the string inverter to stay connected when PV to Battery ratio is  $\leq 100\%$  of rated power per phase, and when PV to battery ratio is  $>100\%$  of rated power per phase, shed the string inverter in off-grid operation. Refer to the tech brief on string inverter configuration on the Documentation center.
- The contacts on the I/O board of the IQ System Controller 3 INT are rated for a maximum of 1 A at 230 VAC RMS. A sample contactor that can be used is Hager ESC425.

### 5.3.5 Solar PV and battery and HEMS: Three-phase IQ7/IQ8 Series Microinverters and IQ Battery 5P with FlexPhase configured in three-phase with IQ System Controller 3 INT and HEMS

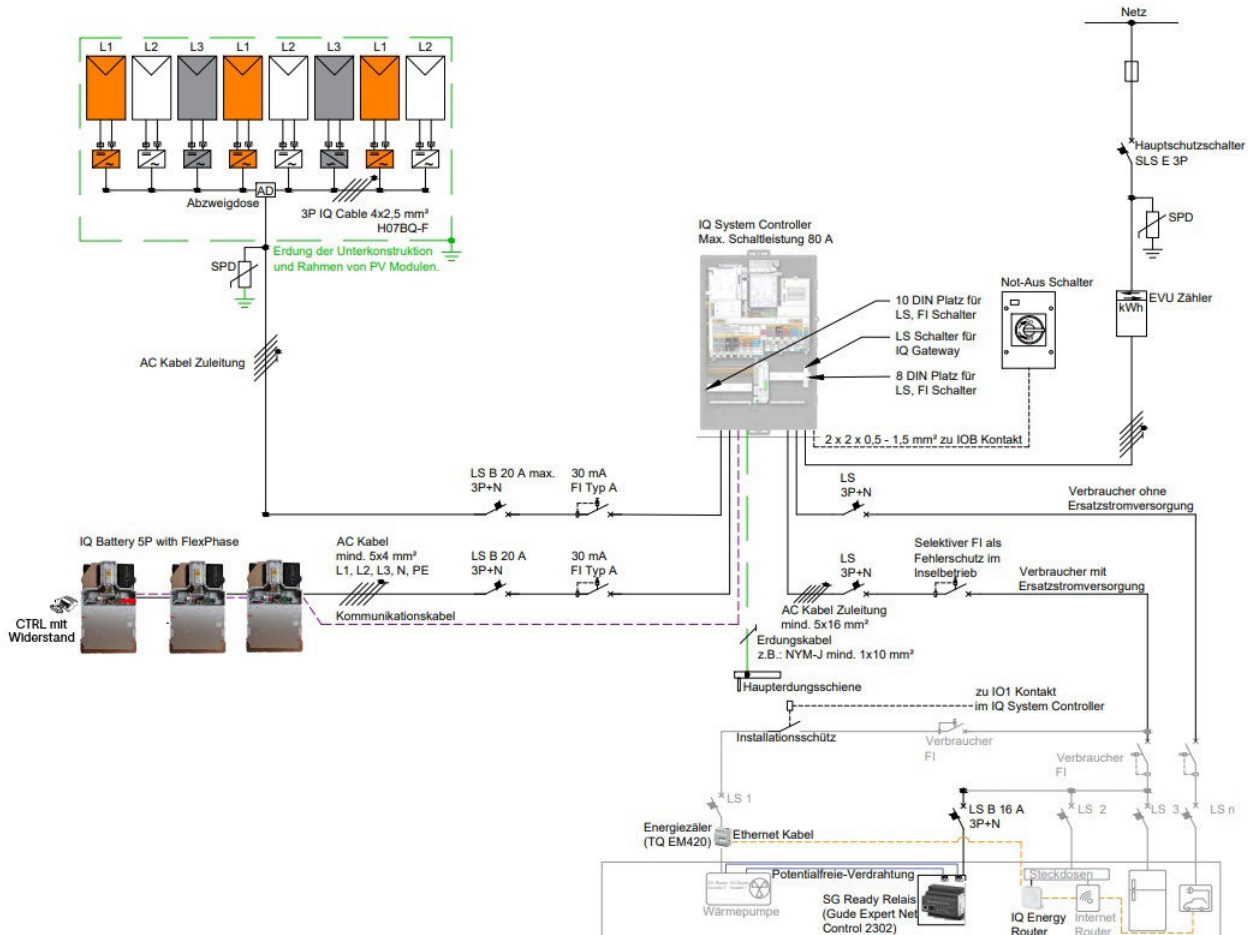

Figure 6: Three-phase IQ7/IQ8 Series Microinverters and IQ Battery 5P with FlexPhase configured in three-phase with IQ System Controller 3 INT and HEMS diagram

For additional configurations single-line diagrams visit the Enphase Documentation center

## 6. Control wiring

An Enphase Energy System communicates over a wired communications interface between the IQ System Controller and IQ Battery 5P.

Use Enphase tested and qualified control cable (order code: CTRL-BL-EU-01) for optimal system performance. Use of non-approved cables can result in system performance issues and loss of warranties.

The following figure shows the guidance for correctly preparing the control (CTRL) cable.

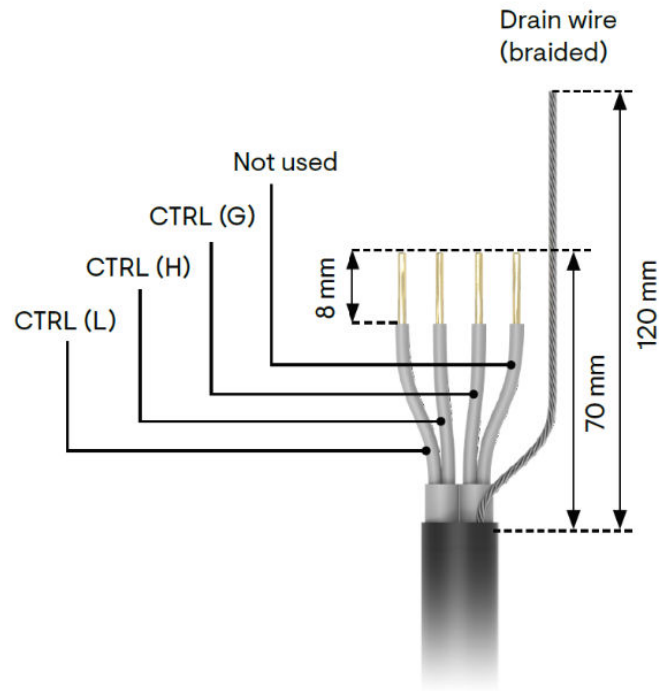

Figure 7: CTRL cable conductors stripping guidance

Table 7 lists the guidance for terminating the conductors of the CTRL cable into the CTRL header for the IQ Battery 5P with FlexPhase and the IQ System Controller.

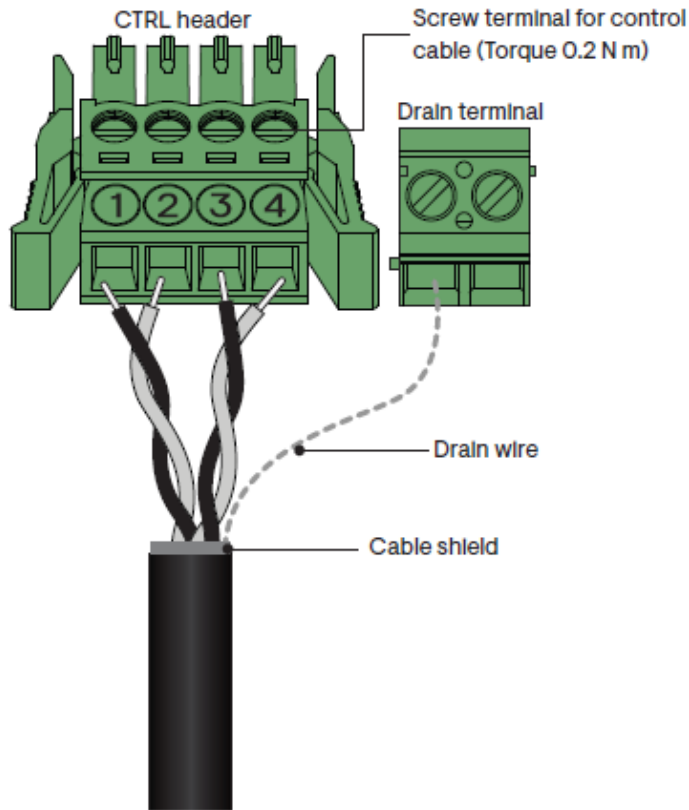

Figure 8: CTRL cable wire landing guidance

Table 7: Enphase Energy-tested control communication cables compatible with IQ Battery 5P

CTRL header numbers	CTRL signals	Conductor designation
Screw terminal 1	CTRL L	White with blue stripe
Screw terminal 2	CTRL H	Blue with white stripe
Screw terminal 3	CTRL G	White with orange stripe
Screw terminal 4	Not used	Orange with white stripe



**NOTE:** The total length of CTRL wiring across the system must not exceed 100 m to ensure optimal system performance.



**NOTE:** Follow the guidelines to avoid failures during system commissioning:

- One header with a termination resistor should be installed on each component that is at the extreme end of the control network.
- The drain wire should be terminated only at one end of each control wiring section or length.
- Terminating the drain wire at the component from which the control wiring for the section is initiated is recommended.

## 6.1 Control wiring guidance for installing IQ Battery 5P with IQ System Controller 3 INT

The following indicative wiring sequences are provided only for guidance and understanding to wire the control network:

### 6.1.1 Sequence 1: IQ Battery 5Ps – IQ System Controller 3 INT

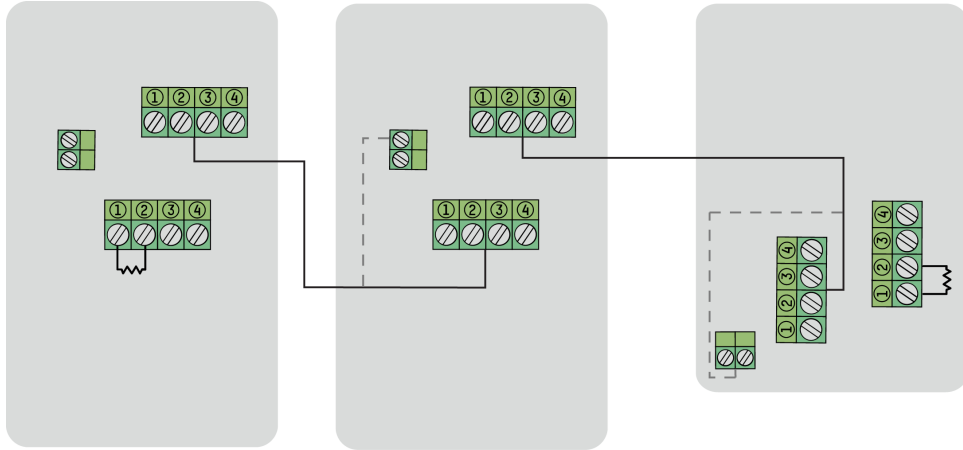

Figure 9: CTRL cable wire sequence 1

### 6.1.2 Sequence 2: IQ Battery 5P – IQ System Controller 3 INT-IQ Battery 5P

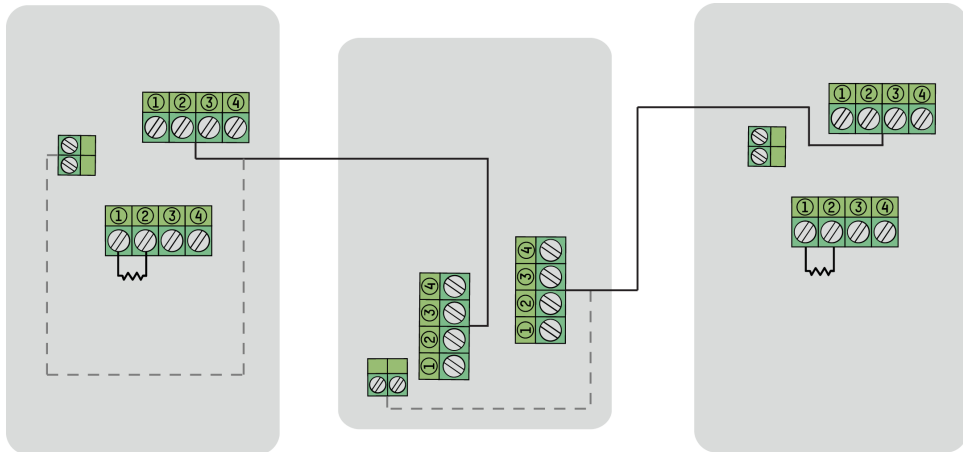

Figure 10: CTRL cable wire sequence 2

The following table lists the termination resistor locations for the preceding sequences.

Table 8: Termination resistor position guidance

Control wiring sequence	Termination resistor location
Sequence 1: IQ Battery 5P with FlexPhase- IQ System Controller 3 INT	Resistor 1: First IQ Battery 5P with FlexPhase in the control bus Resistor 2: IQ System Controller 3 INT

Control wiring sequence	Termination resistor location
Sequence 2: IQ Battery 5P with FlexPhase - IQ System Controller 3 INT - IQ Battery 5P with FlexPhase	Resistors 1 and 2: The two IQ Battery 5P with FlexPhase units at each end of the control bus

## Appendix A

### Enphase components

The following table lists the order code for the Enphase components needed to complete a PV and battery installation. Refer to the IQ7/IQ8 PV and IQ Battery 5P with FlexPhase QIG and data sheet at the Enphase Documentation center to ensure that you select the appropriate components for your installation.

Table 9: Enphase components

Product type	Product	SKU
Enphase microinverters	IQ7 Microinverter	IQ7-60-2-INT IQ7-60-M-INT IQ7A-72-2-INT IQ7A-72-M-INT IQ7PLUS-72-2-INT IQ7PLUS-72-M-INT IQ7X-96-2-INT
	IQ8 Microinverter	IQ8MC-72-M-INT IQ8AC-72-M-INT IQ8HC-72-M-INT
Microinverter accessories	IQ Cable	Three-phase: Q-25-17-3P-160 2.5 mm <sup>2</sup> IQ cable for 60/96-cell, 1.7 m landscape module pitch
		Three-phase: Q-25-17-3P-160 2.5 mm <sup>2</sup> IQ cable for 72-cell, 2.0 m landscape module pitch
		Three-phase: Q-25-10-3P-200 2.5 mm <sup>2</sup> IQ cable for 60/72/96-cell, 1.0 m portrait module pitch
	IQ Terminator	Three-phase: Q-TERM-3P-10
	IQ Sealing Cap	Q-SEAL-10
	IQ Field Wireable Connectors (Female)	Three-phase: Q-CONN-3P-10F
	IQ Field Wireable Connectors (Male)	Three-phase: Q-CONN-3P-10M

Product type	Product	SKU
	Raw IQ Cable (meters)	Three-phase: Q-25-RAW-3P-300
	IQ Cable Clips	ET-CLIP-100
	IQ Disconnect Tool	Three-phase: Q-DISC-3P-10
Enphase battery	IQ Battery 5P with FlexPhase	IQBATTERY-5P-3P-INT
Enphase system controller	IQ System Controller 3 INT	SC100G-M230ROW
Enphase-Belcom control cable	Control cable	CTRL-BL-EU-01

## 7. Revision history

Revision	Date	Description
TEB-00227-1.0	December 2024	Initial release.